

## L4TDM-PS

7-16 DIN Male Positive Stop™ for 1/2 in LDF4-50A cable



## CHARACTERISTICS

### General Specifications

---

Interface	7-16 DIN Male
Body Style	Straight
Brand	HELIAX®   Positive Stop™
Mounting Angle	Straight

### Electrical Specifications

---

Connector Impedance	50 ohm
Operating Frequency Band	0 – 8800 MHz
Cable Impedance	50 ohm
3rd Order IMD	-120 dBm @ 910 MHz
3rd Order IMD Test Method	Two +43 dBm Carriers
RF Operating Voltage, maximum (vrms)	1415.00 V
dc Test Voltage	4000 V
Outer Contact Resistance	1.50 mOhm
Inner Contact Resistance	0.80 mOhm
Insulation Resistance, minimum	5000 MOhm
Average Power	1.1 kW @ 900 MHz
Peak Power, maximum	40.00 kW
Insertion Loss, typical	0.05 dB
Shielding Effectiveness	-110 dB

## Outline Drawing

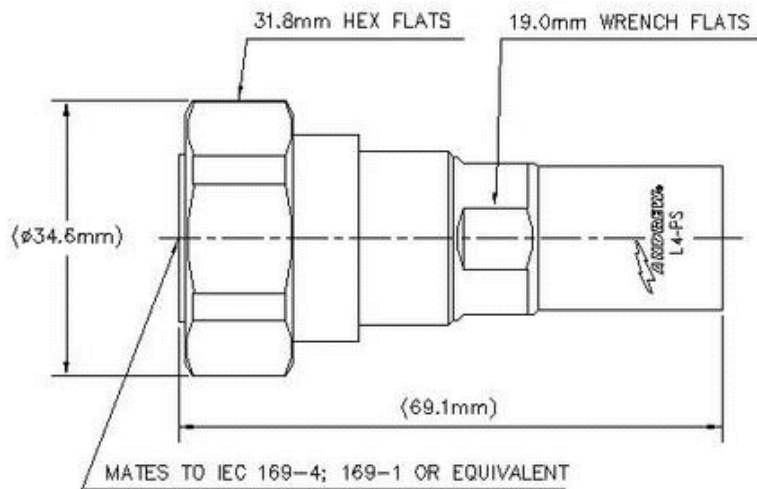

## Mechanical Specifications

Outer Contact Attachment Method	Ring-flare
Inner Contact Attachment Method	Captivated
Outer Contact Plating	Trimetal
Inner Contact Plating	Silver
Attachment Durability	25 cycles
Interface Durability	500 cycles
Interface Durability Method	IEC 169-4:9.5
Connector Retention Tensile Force	890 N   200 lbf
Connector Retention Torque	5.42 N-m   48.00 in lb
Insertion Force	200.17 N   45.00 lbf
Insertion Force Method	IEC 169-1:15.2.4
Pressurizable	No
Coupling Nut Proof Torque	25.00 N-m   221.27 in lb
Coupling Nut Retention Force	1000.00 N   224.81 lbf
Coupling Nut Retention Force Method	MIL-C-39012C-3.25, 4.6.22

## Dimensions

Nominal Size	1/2 in
Diameter, maximum	35.99 mm   1.42 in
Length	68.00 mm   2.68 in

# Product Specifications



L4TDM-PS

Weight 175.00 g | 0.39 lb

## Environmental Specifications

Operating Temperature	-55 °C to +85 °C (-67 °F to +185 °F)
Storage Temperature	-55 °C to +85 °C (-67 °F to +185 °F)
Immersion Depth	1 m
Immersion Test Mating	Unmated
Immersion Test Method	IEC 60529:2001, IP68
Water Jetting Test Mating	Unmated
Water Jetting Test Method	IEC 60529:2001, IP66
Moisture Resistance Test Method	MIL-STD-202F, Method 106F
Mechanical Shock Test Method	MIL-STD-202, Method 213, Test Condition I
Thermal Shock Test Method	MIL-STD-202F, Method 107G, Test Condition A-1, Low Temperature -55 °C
Vibration Test Method	IEC 60068-2-6
Corrosion Test Method	MIL-STD-1344A, Method 1001.1, Test Condition A

## Standard Conditions

Attenuation, Ambient Temperature	20 °C   68 °F
Average Power, Ambient Temperature	40 °C   104 °F

## Return Loss

Frequency Band	VSWR	Return Loss (dB)
45–1000 MHz	1.02	39.00
1010–2200 MHz	1.03	37.00
2200–3000 MHz	1.05	33.00
3010–4000 MHz	1.07	29.00
4010–6000 MHz	1.11	26.00
6010–8000 MHz	1.15	23.00

## Regulatory Compliance/Certifications

Agency	Classification
RoHS 2002/95/EC	Compliant by Exemption
China RoHS SJ/T 11364-2006	Above Maximum Concentration Value (MCV)



## \* Footnotes

# Product Specifications



L4TDM-PS

Immersion Depth      Immersion at specified depth for 24 hours  
Insertion Loss, typical       $0.05\sqrt{\text{freq (GHz)}}$  (not applicable for elliptical waveguide)