

## AL5NM-PS

Type N Male Positive Stop™ for 7/8 in AL5-50 and AVA5-50 cable



## CHARACTERISTICS

### General Specifications

---

Interface	N Male
Body Style	Straight
Brand	HELIAX®   Positive Stop™
Mounting Angle	Straight

### Electrical Specifications

---

Connector Impedance	50 ohm
Operating Frequency Band	0 – 5200 MHz
Cable Impedance	50 ohm
3rd Order IMD	-116 dBm @ 910 MHz
3rd Order IMD Test Method	Two +43 dBm Carriers
RF Operating Voltage, maximum (vrms)	707.00 V
dc Test Voltage	2000 V
Outer Contact Resistance	0.30 mOhm
Inner Contact Resistance	2.00 mOhm
Insulation Resistance, minimum	5000 MOhm
Average Power	0.6 kW @ 900 MHz
Peak Power, maximum	10.00 kW
Insertion Loss, typical	0.05 dB
Shielding Effectiveness	-130 dB

## Outline Drawing

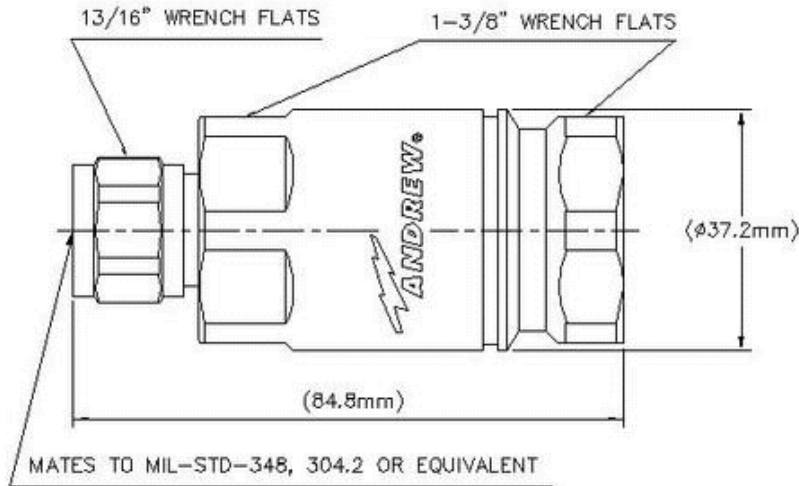

## Mechanical Specifications

Outer Contact Attachment Method	Ring-flare
Inner Contact Attachment Method	Captivated
Outer Contact Plating	Trimetal
Inner Contact Plating	Silver
Attachment Durability	25 cycles
Interface Durability	500 cycles
Interface Durability Method	IEC 169-16:9.5
Connector Retention Tensile Force	1334 N   300 lbf
Connector Retention Torque	8.13 N-m   72.00 in lb
Insertion Force	66.72 N   15.00 lbf
Insertion Force Method	MIL-C-39012C-3.12, 4.6.9
Pressurizable	No
Coupling Nut Proof Torque	4.52 N-m   40.00 in lb
Coupling Nut Retention Force	444.82 N   100.00 lbf
Coupling Nut Retention Force Method	MIL-C-39012C-3.25, 4.6.22

## Dimensions

Nominal Size	7/8 in
Diameter, maximum	37.21 mm   1.47 in
Length	86.11 mm   3.39 in

# Product Specifications



AL5NMPS

Weight 308.20 g | 0.68 lb

## Environmental Specifications

Operating Temperature	-55 °C to +85 °C (-67 °F to +185 °F)
Storage Temperature	-55 °C to +85 °C (-67 °F to +185 °F)
Immersion Depth	1 m
Immersion Test Mating	Unmated
Immersion Test Method	IEC 60529:2001, IP68
Water Jetting Test Mating	Unmated
Water Jetting Test Method	IEC 60529:2001, IP66
Moisture Resistance Test Method	MIL-STD-202F, Method 106F
Mechanical Shock Test Method	MIL-STD-202F, Method 213B, Test Condition C
Thermal Shock Test Method	MIL-STD-202F, Method 107G, Test Condition A-1, Low Temperature -55 °C
Vibration Test Method	IEC 60068-2-6
Corrosion Test Method	MIL-STD-1344A, Method 1001.1, Test Condition A

## Standard Conditions

Attenuation, Ambient Temperature	20 °C   68 °F
Average Power, Ambient Temperature	40 °C   104 °F

## Return Loss

Frequency Band	VSWR	Return Loss (dB)
50–1000 MHz	1.02	39.00
1010–2200 MHz	1.03	38.00
2210–3000 MHz	1.04	35.00
3010–4000 MHz	1.07	29.00
4010–5200 MHz	1.13	24.00

## Regulatory Compliance/Certifications

Agency	Classification
RoHS 2002/95/EC	Compliant by Exemption
China RoHS SJ/T 11364-2006	Above Maximum Concentration Value (MCV)



## \* Footnotes

Immersion Depth Immersion at specified depth for 24 hours

# Product Specifications



AL5NM-PS

Insertion Loss, typical  $0.05\sqrt{\text{freq (GHz)}}$  (not applicable for elliptical waveguide)